



Since 1971



Over 80 countries



BC-2200



BC-1800



BC-2800



**BC-3200JV
BC-3200LHS**



SIERRAS CINTA · BANDSAWS · BANDSÄGEN · SEGAOSSA · SCIES À OS

www.mainca.com

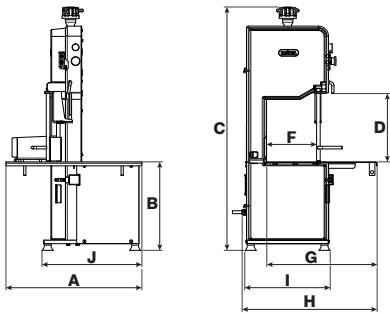

mm	A	B	C	D	F	G	H	I	J	Ø	L
BC-1800	551	328	896	175	200	444	531	298	366	230	1750
BC-2200	605	398	1170	310	233	496	606	381	442	275	2280
BC-2800	765	894	1786	352	280	635	755	553	602	300	2720
BC-3200JV BC-3200LHS	847	906	1896	400	310	715	837	581	606	330	3060

Ø : Rueda / Wheel / Rad / Puleggia / Roue

L : Longitud Cinta / Band Length / Band-Länge / Lunghezza lama / Longuer lame

CARACTERÍSTICAS TÉCNICAS - TECHNICAL DATA - TECHNISCHE DATEN - CARACTERISTICHE TECNICHE - CARACTERISTIQUES TECHNIQUES		BC-1800	BC-2200	BC-2800	BC-3200JV BC-3200LHS
Motores - Motors - Motoren - Motore - Moteurs:					
III, 230-400V, 50 Hz	HP / kW	1,5 / 1,10	1,75 / 1,20	3,0 / 2,20	4,00 / 2,90
II, 230V, 50 Hz	HP / kW	1,5 / 1,10	1,5 / 1,10	2,5 / 1,84	3,50 / 2,60
Peso Neto - Net Weight - Netto Gewicht - Pesseo Netto - Poids net:	Kg	55	65	126	160

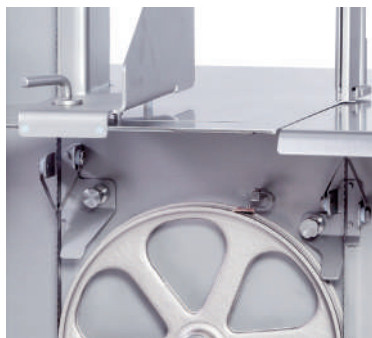

Sierras Cinta

Construidas con chasis compactos indeformables. Indicadas para cortar carne fresca con hueso o congelado. Efectúan unos cortes limpios gracias a los dispositivos de limpieza de la cinta. Se elimina el problema de astillas de los cortes a mano. Reduce casi al 50% la merma respecto al corte manual. Superficie interior lisa y muy fácil de limpiar puesto que los elementos mecánicos están separados de los elementos de corte. Dotadas de la máxima seguridad (freno motor con parada en > 4 segundos al accionar botón paro o al intentar abrir la puerta). Equipadas con apretador basculante. Construcción: totalmente en acero inoxidable.

OPCIONES:

Tensor automático de la cinta y cajetín recolector de merma (de serie en la BC-2800 / BC-3200).
Mesa de corte móvil.
Pie soporte al suelo.
BC-3200LHS: Modelo con la columna a la derecha.

Bandsaws

Designed to satisfy the most demanding cutting needs of butchers and meat processors. Ideal for cutting fresh meat with bones or frozen meat. The wheels and blade scraper assemblies are designed to offer the best cutting performance. It eliminates splinters caused by hand chopping. Inner chassis with smooth surfaces and rounded corners for easy cleaning. Equipped with maximum safety features: brake motor operation within 4 seconds either by the stop button or when opening the door. Supplied with a hinged pusher. They include an extractor fan in the motor housing to reduce the chance of overheating (optional on table top models). Construction: completely made of stainless steel.

OPTIONS:

Automatic blade tightener and waste box (standard on models BC-2800 / BC-3200).
Half sliding table.
Tubular Stand Inox.
BC-3200LHS: Model with column on the right side.

Bandsägen

Mit einem kompakten und unverformbaren Körper gebaut. Besonders geeignet für Frischfleisch mit Knochen und Tiefgefrorenem. Sägt absolut sauber dank der Bandreinigungs-Vorrichtungen. Vermeidet die Bildung von Knochensplintern. Reduziert bis zu 50% an Materialverlust im Vergleich zum Hand-schnitt. Mit glatter Oberfläche innen für eine bequeme Reinigung. Höchste Sicherheit (Motorbremse greift in bis zu 4 sec. bei Drücken der Notschalttaste und bei Öffnen der Tür. Incl. Materialdrücker. Konstruktion: aus Edelstahl.

OPTIONEN:

Automatic Band-Spannung und Knochenmehlbehälter (Standard für BC-2800 / BC-3200).
Beweglicher Halbtisch.
Untergestell aus Edelstahl.
BC-3200LHS: Maschine mit Sägeband linksseitig.

Segaossa

Costruita con telaio compatto indeformabile. Indicada per tagliare carne fresca con ossa e congelata. Esegue tagli puliti grazie ai dispositivi di pulizia del nastro. Viene eliminato il problema schegge dei tagli a mano. Riduce del 50% il consumo rispetto al taglio manuale. Superficie interna liscia e molto facile da pulire visto che gli elementi meccanici sono separati dagli elementi di taglio. Dotate della massima sicurezza (freno motore con arresto in >4 secondi dal momento dell'azionamento del pulsante di arresto o all'apertura della porta). Fornita di stringitrice. Costruzione: in acciaio inox.

OPZIONI:

Tensor automatico di lama e Raccogliatore di segatura (Standard per la BC-2800 / BC-3200).
Tavola mobile inoss.
Struttura d'appoggio inoss.
BC-3200LHS: Modello con la colonna a la destra.

Scies à os

Construites avec des chassiss compacts indéformables. Apte pour la viande fraîche avec os, congelés et os. Grâce aux dispositifs de propreté la lame coupe la viande proprement. On élimine le problème de formation d'esquilles quand on coupe l'os par rapport à la coupure manuelle. Réduit de 50% la perte par rapport à la coupure manuelle. Surface intérieure lisse et très facile à nettoyer. Sécurité d'usage maximale (Arrêt de lame en >4 secondes en actionnant le bouton d'arrêt ou en essayant d'ouvrir la porte). Equipé avec protecteur basculeur. Construction: en acier inox.

OPTIONS:

Tendeur lame automatique et Boîte à sciure (Standard pour la BC-2800 / BC-3200).
Table déplaçable inox.
Podium inox.
BC-3200LHS: Modèle avec colonne à droit.



EQUIPAMIENTOS CARNICOS, S.L.

Pol. Ind. "Coll de la Manya" - C/ Jaume Ferran, 1-7
E-08403 GRANOLLERS (Barcelona) SPAIN
Tel. (+34) 938 491 822 / Fax: (+34) 938 497 176

www.mainca.com / mainca@mainca.com

